

COMPACT EXCAVATOR

TakeuchiTM
From World First to World Leader

TB216



Operating Weight: 1,770 kg

Product Features & Specifications

ENGINE

- EU Stage V / EPA Tier 4 Emission Compliant
- Engine Preheat
- Extended Life Coolant
- Double Element, Air Cleaner (optional)
- Automatic Fuel Bleed System
- High Capacity Fuel Filters
- Engine Safety Start System on the Left Console

ELECTRICAL

- Color Multi-Informational Display
- 12 volt System with 40 amp Alternator
- 2 Canopy Lights
- 1 Working Light on Boom
- 1 Cab Front Light (Cab Only)
- Beacon Socket (Cab Only)
- TFM (Takeuchi Fleet Management; GPS) (optional)*
- TSS (Takeuchi Security System; Immobilizer) (optional)*
- Hour Meter
- Travel Alarm (optional)

UNDERCARRIAGE AND FRAME

- Triple Flanged Track Rollers
- Hydraulically Retractable Track Frame (980 mm to 1,300 mm)
- Adjustable Width Backfill Blade
- 2-Speed Travel with Automatic Shift
- Wraparound Protective Counterweight
- 230 mm Rubber Crawlers
- 230 mm Steel Crawlers (optional)

OPERATOR'S STATION

- ROPS / TOPS / OPG (Top Guard, Level I)
- 12V Power Outlet
- Highback Suspension Adjustable Seat
- Bluetooth Radio (Cab Only)
- 2" Retractable Seat Belt
- Heater for Defrosting and Demisting (Cab Only)
- OPG Level I Front Guard (Cab Optional)

TAKEUCHI FLEET MANAGEMENT

- Minimize Downtime
- Remote Diagnostics
- Utilization Tracking
- Proactive Maintenance
- Control Costs

HYDRAULIC

- Variable Displacement Pump
- Straight Travel Circuit
- Hydraulic Joystick Controls
- Foot Pedal Control for Service Port 1
- Auxiliary Hydraulic Circuit Plumbed to Arm
- Hydraulic Tank with Fluid Level Sight Gauge
- Proportional Control for Service Port 2 (optional)
- Service Port 3 for Quick Hitch (optional)
- Hydraulic Selector Valve (1-way/2-way) (optional)
- Pilot Accumulator (optional)

WORKING EQUIPMENT

- Independent Mono Boom Swing
- Cushioned Boom and Swing Cylinders
- Top Mount Boom Cylinders
- 930 mm Arm
- 1,130 mm Arm
- Arm and Boom Holding Valve with Lift Alarm (optional)
- Pattern Change Valve (ISO or G) (optional)
- Boom Swing Stopper (optional)



Halogen Work Lights



Wraparound Counterweight

*Functions may not be available in all countries, so please consult your Takeuchi dealer for details.

TOUGH, POWERFUL, RELIABLE



Top Mount Boom Cylinder



Convenient Filter Access



High Capacity Cooling



Two-Speed Travel

The TB216 has a wide range of features to make any job easier. Standard equipment includes an improved multi-informational display, two-speed travel, pilot operated joystick controls, a high capacity cooling system, and convenient filter and service access.

The boom comes equipped with a topside boom cylinder and the hydraulic plumbing is well protected within the boom and arm.

Auxiliary hydraulics and boom pivot are controlled using the foot pedals located on the left and right side of the floor. An optional pattern change valve is conveniently positioned inside the seat pedestal.

The TB216 is rugged, dependable, and productive. It provides exceptional value, and demonstrates outstanding performance.



Easy Maintenance and Service Access

OPERATING PERFORMANCE	Serial No. 216000002 or later	Serial No. 216100002 or later
Operating Weight - Cab	1,865 kg	N/A
Operating Weight - Canopy	1,770 kg	
Bucket Capacity (Heaped)	0.038m ³	
Slew Speed	9.2 min ⁻¹	
Travel Speed		
1st	2.2 km/h	
2nd	4.2 km/h	
Gradeability	15°	
Ground Pressure - Cab	31.0 kPa	N/A
Ground Pressure - Canopy	29.4 kPa	
Maximum Bucket Breakout Force	14 kN	
Maximum Arm Digging Force (930 mm Arm)	9.5 kN	
Maximum Arm Digging Force (1,030 mm Arm)	8.2 kN	
Traction Force	19.4 kN	
Boom Swing Angle (Left/Right)	80° / 50°	

ENGINE

	Yanmar 3TNV70	Yanmar 3TNV74
Model		
Rated Output (ISO 14396)	11.5 kW / 2,400 min ⁻¹	11.2 kW / 2,400 min ⁻¹
Maximum Torque	52.7 Nm / 1,800 min ⁻¹	51.8 Nm / 1,800 min ⁻¹
Displacement	854 ml	993 ml
Alternator	12 V - 0.48 kW	
Battery (IEC 60095-1)	12 V - 45 A·h	

FLUID CAPACITY

Engine Lubrication	2.8 L
Cooling System	3.8 L
Fuel Tank Capacity	22.0 L
Hydraulic Reservoir Capacity	16.0 L
Hydraulic System Capacity	24.5 L

HYDRAULIC SYSTEM	Serial No. 216000002 or later	Serial No. 216100002 or later
P1, P2	Variable Displacement Pump	
Flow Rate	16.8 L/min	
Relief Pressure	21.0 MPa	
P3	Gear Pump	
Flow Rate	10.8 L/min	
Relief Pressure	20.0 MPa	
Service Port 1		
Flow Rate	33.6 L/min	
Hydraulic Pressure	21.0 MPa	
Service Port 2		
Flow Rate	10.8 L/min	
Hydraulic Pressure	20.0 MPa	
Service Port 3		
Hydraulic Pressure	20.0 MPa	

SAFETY and HEALTH

Vibration Levels		
Hand / Arm		≤ 2.5 m/s ²
Body		≤ 0.5 m/s ²
Noise Level		
Sound Power Level		LWA 93 dB



Multi-Informational Display



Retractable Undercarriage



Top Mount Boom Cylinder

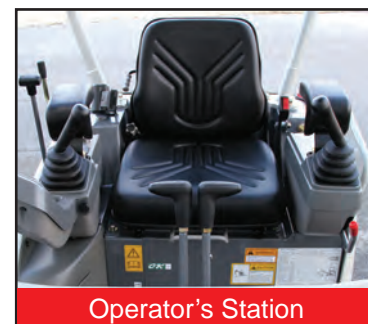

Operator's Station

TB216 Compact Excavator

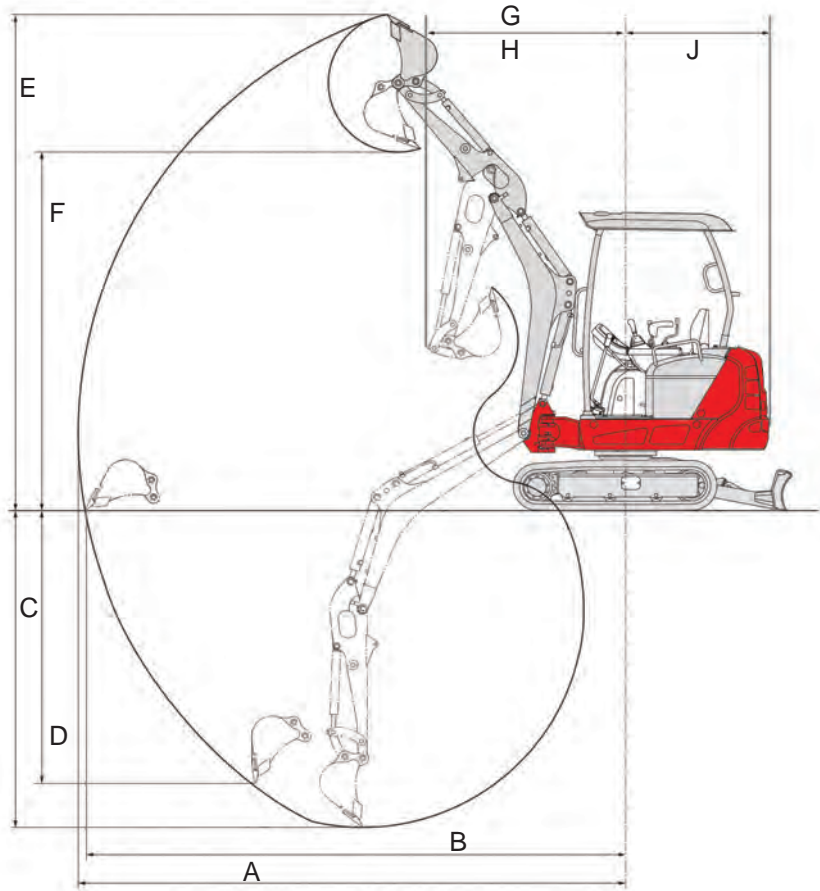
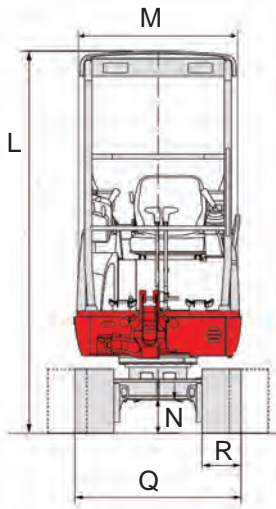
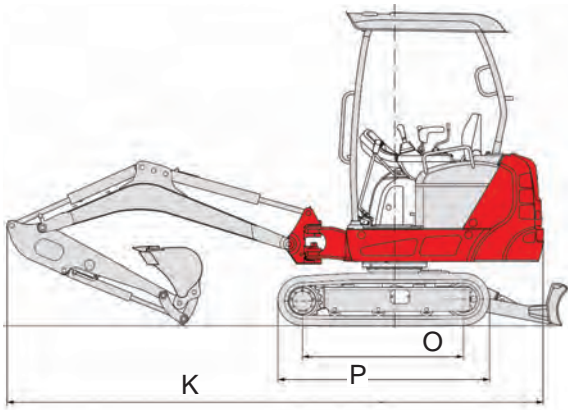

MACHINE DIMENSIONS		930 mm Arm	1,130 mm Arm
A	Maximum Reach	3,900 mm	4,090 mm
B	Maximum Reach at Ground Level	3,845 mm	4,035 mm
C	Maximum Digging Depth	2,190 mm	2,390 mm
D	Maximum Vertical Digging Depth	1,870 mm	2,060 mm
E	Maximum Height of Cutting Edge	3,590 mm	3,740 mm
F	Maximum Dumping Height	2,550 mm	2,705 mm
G	Front Swing Radius	1,435 mm	1,480 mm
H	Front Swing Radius with Boom Offset	1,120 mm	1,155 mm
J	Slew Radius	1,075 mm	
K	Overall Length	3,875 mm	3,870 mm
L	Overall Height (Cab / Canopy)	2,360 mm / 2,280 mm	
M	Upper Structure Overall Width (Cab / Canopy)	1,055 mm / 985 mm	
N	Ground Clearance	205 mm	
O	Crawler Base	1,155 mm	
P	Crawler Overall Length	1,520 mm	
Q	Crawler Overall Width - Crawler Retracted	980 mm	
Q'	Crawler Overall Width - Crawler Extended	1,300 mm	
R	Crawler Shoe Width	230 mm	

